



# CANR110NO20

## Information Guide



THIS PAGE IS INTENTIONALLY LEFT BLANK

Product Number	Version	Version Date
CANR110NO20	R3	04 – DECEMBER – 2023

This document is electronically controlled. Any printed copies of this document may be used for reference but unless they are clearly marked as "Controlled Document" they are to be treated as uncontrolled documents.

## Table of Contents

- 1. Safety Precautions..... 4
- 2. Specifications..... 4
- 3. Quick Start Guide – CANR110NO20..... 5
- 4. CANR110NO20 Dimensions, Mounting Options, and Orientations..... 6
- 5. Mounting and Installation Options..... 8
  - 5.1 CANGOEE CANR110 Mounting Rack System (Optional) ..... 8
- 6. CANR110NO20 Example Use Case Schematics ..... 9
- 7. Recommended Wire Sizes and Gauges Chart ..... 10
- 8. Wiring Schematic ..... 11
  - 8.1 Active MCP Pinout..... 11
  - 8.2 System Setup WITHOUT a Shunt ..... 11
  - 8.3 System Setup WITH a Shunt..... 11
- 9. DC-DC Charger..... 12
  - 9.1 Measured Voltage ..... 12
  - 9.2 Delay Switch ..... 13
  - 9.3 Off-Delay ..... 13
  - 9.4 On-Delay ..... 13
  - 9.5 Ignition Signal ..... 13
- 10. Battery Management System ..... 14
  - 10.1 BMS Off Functionality ..... 14
- 11. Safety Tips ..... 15
- 12. Longevity Tips ..... 15
- 13. Tips for Use ..... 16
- 14. Maintenance Tips..... 16

THIS PAGE IS INTENTIONALLY LEFT BLANK

Product Number	Version	Version Date
CANR110NO20	R3	04 – DECEMBER – 2023

This document is electronically controlled. Any printed copies of this document may be used for reference but unless they are clearly marked as "Controlled Document" they are to be treated as uncontrolled documents.

## 1. Safety Precautions

### WARNING

- ❑ Avoid mechanical shock.
- ❑ Avoid direct sunlight exposure.
- ❑ Do not store or mount batteries in incorrect orientations.
- ❑ Do not transport the battery unsecured.
- ❑ Do not expose the battery to water.
- ❑ Do not expose the battery to fire.
- ❑ Do not pierce the battery.
- ❑ Do not disassemble.
- ❑ Do not drill into the battery enclosure.
- ❑ Do not short battery terminals.
- ❑ Do not connect multiple batteries in a series configuration.
- ❑ Do not charge the battery outside the range of 0°C – 45°C.
- ❑ Do not store below -20°C or above 60°C.
- ❑ Risk of burns if misused.
- ❑ Always follow safe working practices.
- ❑ Installation of this device must only be carried out by appropriately qualified competent person(s).
- ❑ All connections must be fused at recommended fuse ratings to avoid damage to components.
- ❑ All minimum cable gauges and maximum lengths must be followed.
- ❑ Only use Lithium Battery Chargers to recharge batteries.

## 2. Specifications

Cell Type	Lithium Ferrous Phosphate
<b>Total Capacity</b>	110Ah
<b>Nominal Voltage</b>	12.8V
<b>Charge Voltage</b>	13.8 – 14.6V
<b>Float Voltage</b>	13.8V
<b>Charge Current</b>	100A
<b>Discharge Current</b>	100A Continuous/ 200A Surge
<b>DC-DC Charger</b>	20A
<b>Operating Temp</b>	0°C – 45°C
<b>Dimensions (LxWxD)</b>	332.5 mm x 227.5 mm x 141.5 mm

Table 1 CANR110NO20 Power Node Specifications

### 3. Quick Start Guide – CANR110NO20

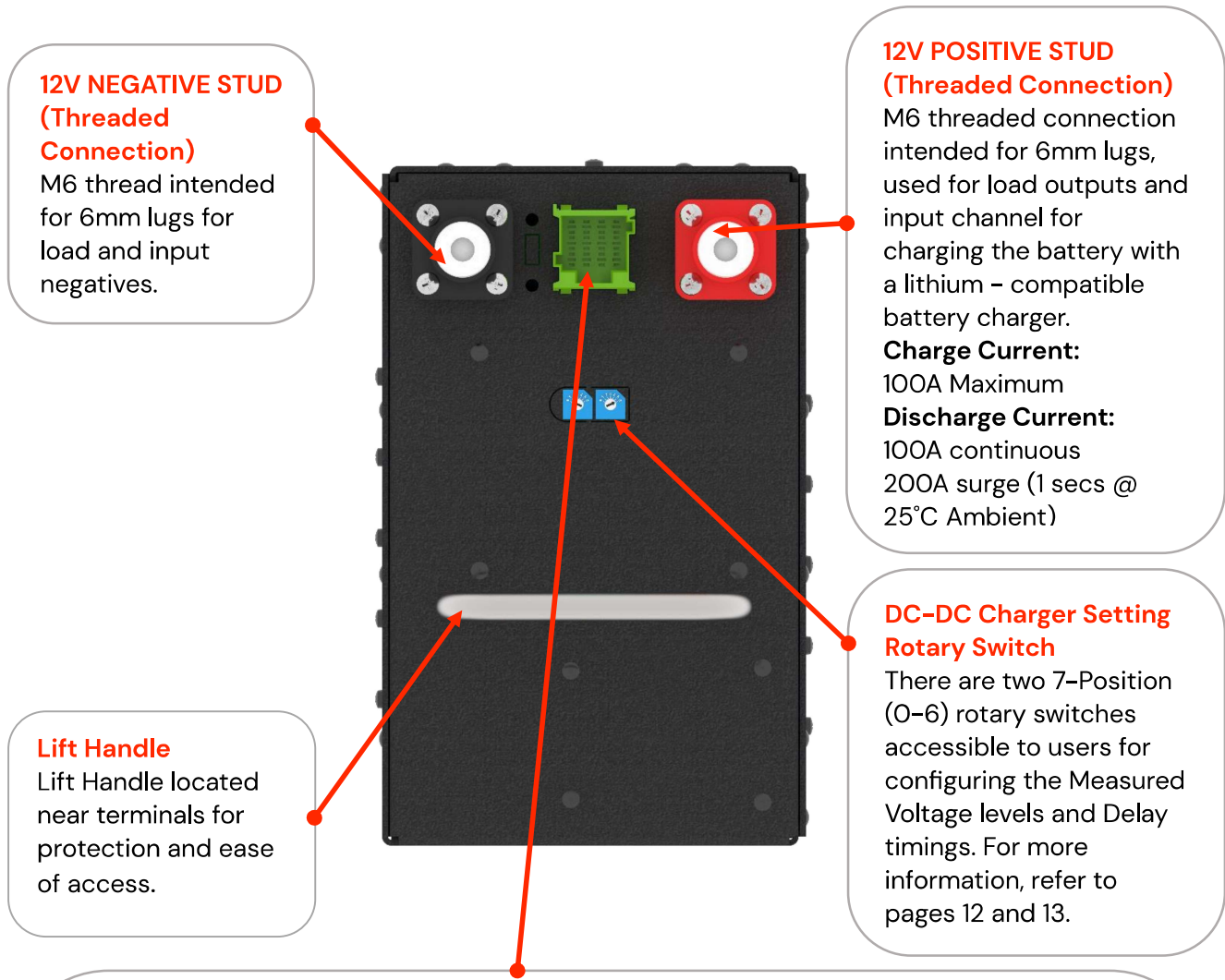

#### 12 WAY MULTI-CONTACT POINT (MCP) CONNECTOR

The MCP Connector serves as the access point to the internal features of the battery. Connection to the internal 20A DCDC Charger is established via this port and the individual Lithium Cell voltage readings can be used for servicing the battery and fault finding – these correspond to PIN 1 through to PIN 5 – **DO NOT TOUCH THESE PINS**. Other active MCP Pins are detailed in the table below.

#### ACTIVE MCP PINOUT:

PIN 06:	DCDC +VE
PIN 07:	DCDC -VE
PIN 08:	IGNITION SENSE
PIN 12:	BMS OFF

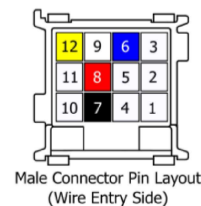

Table 2 Active MCP Pinout with Male Connector Pin Layout

Figure 1 Power Node Connection Description

#### 4. CANR110NO20 Dimensions, Mounting Options, and Orientations

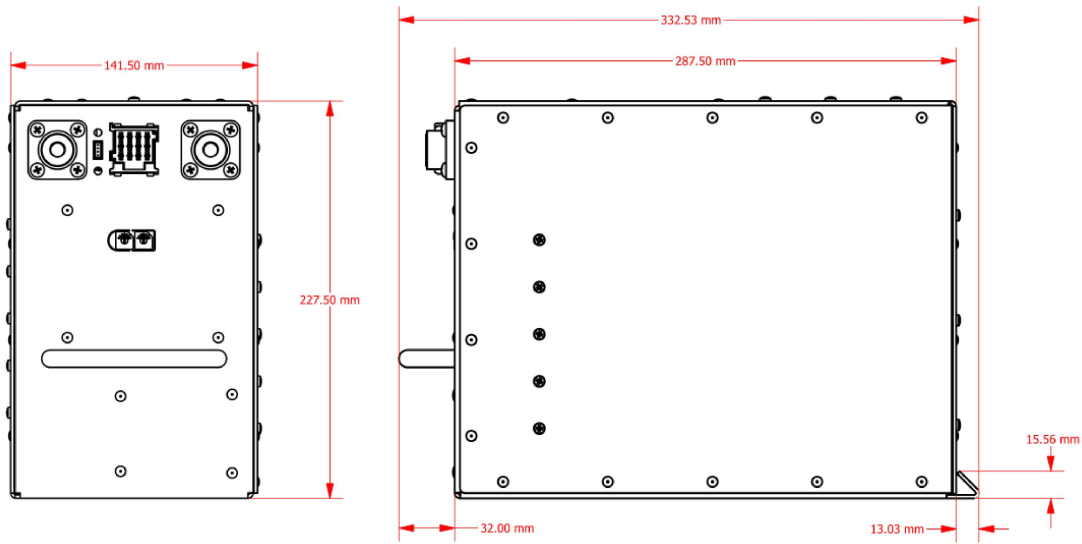

Figure 2 CANR110NO20 Dimensions

The CANR110 batteries are equipped with mounting tabs at the rear of the unit, allowing for various mounting options available separately. These options range from singular mounting brackets which consist of a lift handle and angle bracket to purpose-built mounting rack systems designed to securely house multiple units of the CANR110 Series products.

The lift handle bracket and the angle bracket are shown in Table 3. Purpose-built CANGOEE Mounting Rack Systems come in different options designed to fit 2, 3, or 6 units of the CANR110 series products. Please see page 8 for more details on the CANGOEE CANR110 Mounting Rack System

Example mounting orientations are shown on page 7.

Singular CANR110 Series Unit Mounting Bracket Options	
CANR110 Series Lift Handle Bracket	CANR110 Series Singular Angle Bracket (Double option also available)

Table 3 Mounting Bracket Options with Example Mounting Diagram for Lift Handle Bracket and Angle Bracket

Product Number	Version	Version Date
CANR110NO20	R3	04 – DECEMBER – 2023

This document is electronically controlled. Any printed copies of this document may be used for reference but unless they are clearly marked as "Controlled Document" they are to be treated as uncontrolled documents.

Example Mounting Orientations		
CORRECT Mounting Orientations		
		
<p>Horizontally on either of its sides.</p>	<p>In upright orientation or upside down.</p>	<p>With the lift handle pointing towards the sky.</p>
INCORRECT Mounting Orientations		
		
<p>Any orientation with the lift handle pointing towards the ground is <b>INCORRECT</b>.  <b>Please Note:</b> Rotary selector switches should ideally be set before installing the Power Node as access may be difficult after installation. Please refer to pages 12 and 13 for details on the rotary selector switch position settings.</p>		

Table 4 Power Node Mounting Orientation Example

Product Number	Version	Version Date
CANR110NO20	R3	04 – DECEMBER – 2023

This document is electronically controlled. Any printed copies of this document may be used for reference but unless they are clearly marked as "Controlled Document" they are to be treated as uncontrolled documents.

## 5. Mounting and Installation Options

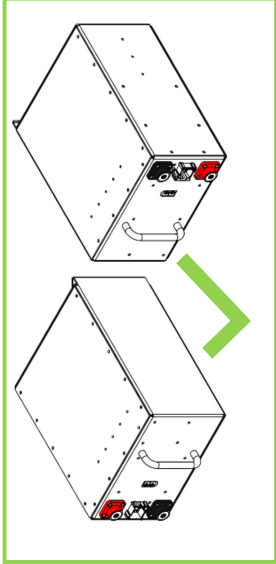
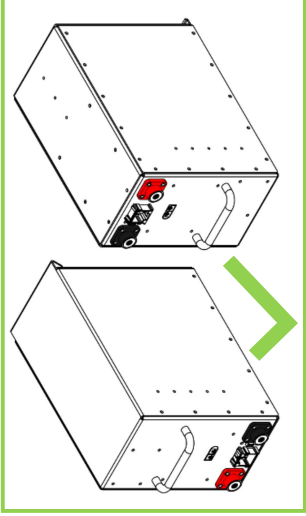
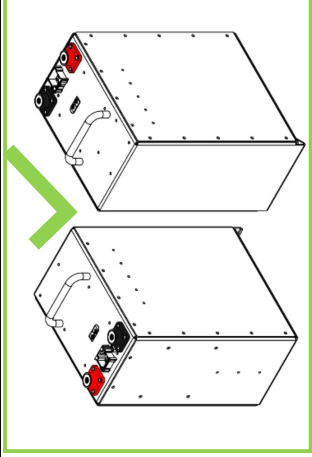
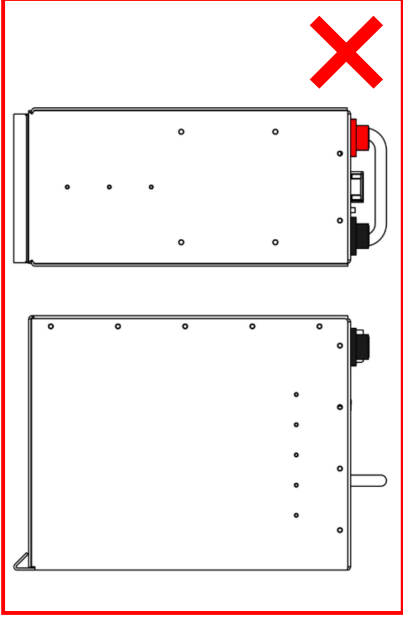
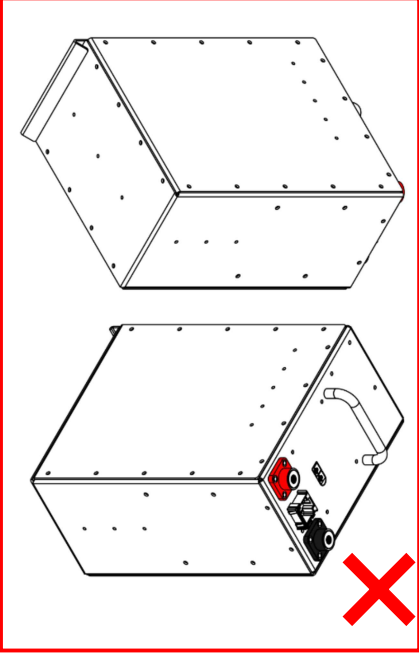
The unit can be installed within the CANGOEE CANR110 Mounting Rack System or by securing it using the lift handle brackets and angle brackets.

Please ensure that appropriate PPE gear is worn when installing the CANR110 series products and that the safety guidelines are followed carefully.

### 5.1 CANGOEE CANR110 Mounting Rack System (Optional)

The CANGOEE CANR110 Mounting Rack System allows for multiple units of the CANR110BA and CANR110BA2 Power Banks and CANR110 series Power Nodes or Power Hubs to be placed into the same rack bay for easy modularity of the overall power system.

By utilising a configuration consisting of multiple units of the CANR110 series Power Banks, Power Nodes, or Power Hubs, a separate bus bar system is employed for both the negative and positive terminals. This simplifies the connection to the power system, requiring only a single positive and a single negative connection – for recommended wire sizes and gauges for connections, please see the table on page 10.

CANGOEE CANR110 Mounting Rack System Options	
	<p><b>2 Bay Mounting Rack System</b></p> <p>Example System - 1 x CANR110NO20 Power Node + 1 x CANR110BA2 Power Bank = 220Ah System</p>
	<p><b>3 Bay Mounting Rack System</b></p> <p>Example System - 1 x CANR110NO20 Power Node + 2 x CANR110BA2 Power Banks = 330Ah System</p>
	<p><b>6 Bay Mounting Rack System</b></p> <p>Example System - 1 x CANR110NO20S15 Power Hub + 3 x CANR110BA Power Banks + 2 x CANR110BA2 Power Banks = 660Ah System</p>

Table 5 CANGOEE CANR110 Mounting Rack System Options

## 6. CANR110NO20 Example Use Case Schematics

**Please Note:** This is for illustration purposes only and is **NOT** intended to be used as a guide for installation.

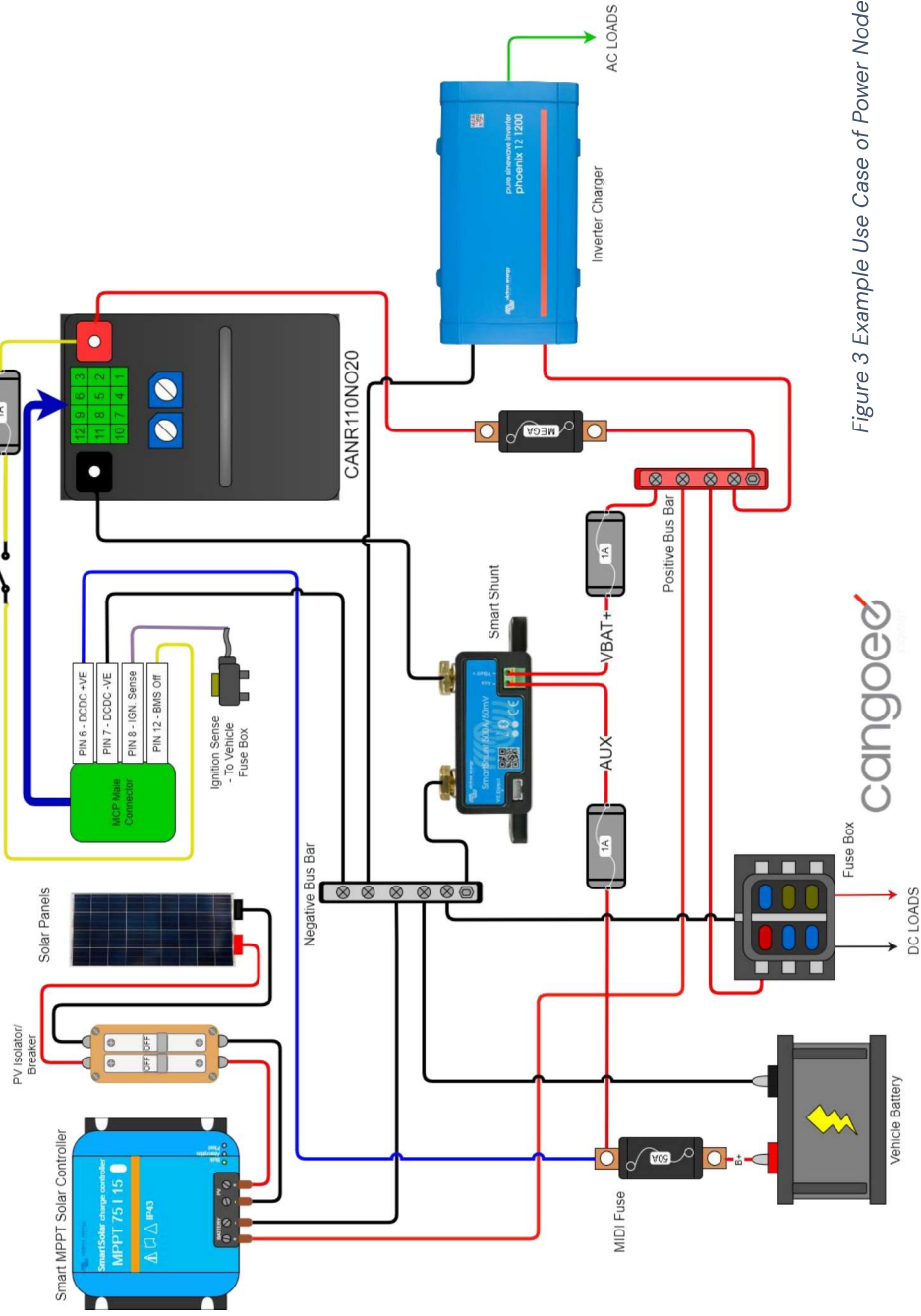

Figure 3 Example Use Case of Power Node



## 7. Recommended Wire Sizes and Gauges Chart

The below table represents the recommended wire sizes/ gauges, for battery installation into vehicles.

DCDC Capacity/ Cable	Recommended Wire Size/ Gauge Figure 8 Cable	Recommended Wire Length
DC-DC 20A	8 B&S/ AWG (CSA 7.71mm <sup>2</sup> )	1m- Up to/ Maximum 5m
DC-DC 40A	6 B&S/ AWG (CSA 13.5mm <sup>2</sup> )	1m – Up to/ Maximum 5m
Ignition Sense Cable	18-14 B&S/ AWG (CSA 0.64mm <sup>2</sup> – 1.84mm <sup>2</sup> ) (Running a max of 1-2 Amps)	1m – Up to/ Maximum 6m
Main Positive +	6 B&S/ AWG (CSA 13.5mm <sup>2</sup> ) 80A – 120A	1m – Up to/ Maximum 4m
Main GND -	6 B&S/ AWG (CSA 13.5mm <sup>2</sup> ) 80A – 120A	1m – Up to/ Maximum 4m

Table 6 Recommended Wire Sizes and Gauges

**Please Note:** These wire gauges are suggested to mitigate the voltage drop along the cable. It is recommended that you check the voltage at the battery's DC-DC input and alter charger selector switches accordingly.

## 8. Wiring Schematic

### 8.1 Active MCP Pinout

PIN 06:	DCDC +VE
PIN 07:	DCDC -VE
PIN 08:	IGNITION SENSE
PIN 12:	BMS OFF

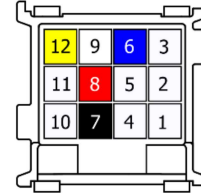

Male Connector Pin Layout  
(Wire Entry Side)

Table 7 Active MCP Pinout with Male Connector Pin Layout

**Please Note:** The following diagrams of system setups with and without a Shunt are for illustrative purposes only and are **NOT** intended to be used as a guide for installation.

### 8.2 System Setup WITHOUT a Shunt

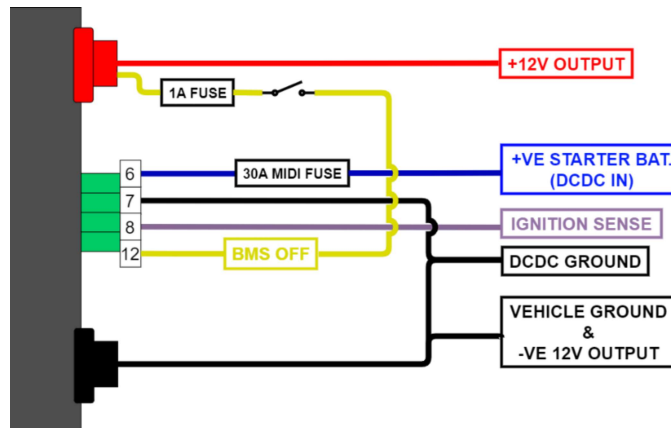

Figure 4 Example Wiring Schematic of System Setup WITHOUT a Shunt

### 8.3 System Setup WITH a Shunt

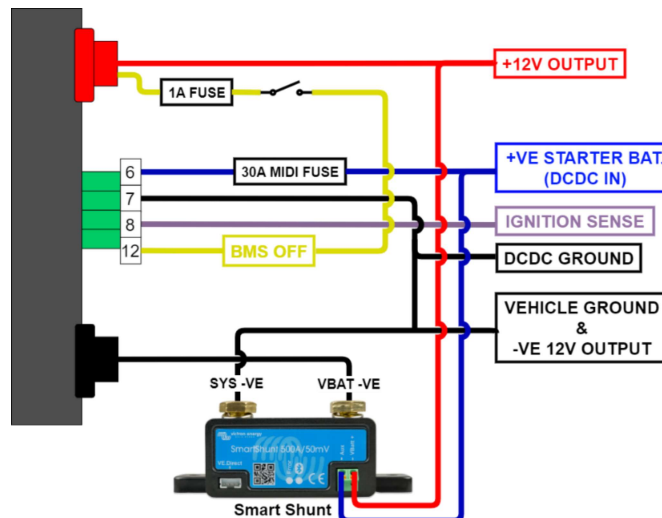

Figure 5 Example Wiring Schematic of System Setup WITH a Shunt

## 9. DC-DC Charger

The DC-DC charger in the Power Hub allows the battery to charge from a vehicle engine/ alternator/ start battery. However, to prevent the depletion of the start battery, it is essential to limit charging to when the engine is actively running.

In some scenarios, determining when the engine is actively operating can be challenging. As a solution, the DC-DC charger uses a combination of inputs to decide when to initiate charging (turn ON) and when to cease charging (turn OFF). The primary goals of the charger are:

- ❑ Ensuring that charging occurs only when the engine is actively running, to maximise charging of the Power Node.
- ❑ Preventing charging when the engine is not running to avoid discharging the vehicle’s start/cranking battery.

The logic for controlling when to activate or deactivate the DC-DC charger is executed through specialised software running on a microcontroller. This software allows for advanced control by considering several inputs including:

- ❑ Start battery voltage.
- ❑ Ignition signal voltage.
- ❑ Timing delays.
- ❑ Positions of 2 x 7-position (0-6) rotary switches: user-accessible from outside the battery.

### 9.1 Measured Voltage

The vehicle’s start battery/ alternator voltage will be measured with high precision, accurate to  $\pm 0.1V$  or better, and used as a reference for comparison with the ON and OFF levels.

The DC-DC Charger will be activated (start charging) when the **Measured Voltage** goes ABOVE the **ON Level**. Thereafter it will deactivate after the **Measured Voltage** goes BELOW the **OFF Level**.

The OFF level is lower than the ON Level by 1.0V; this forms a “dead-band” where the charger will simply remain in the same state (i.e., remain ON if already ON, and remain OFF if already OFF).

ON and OFF Levels can be selected by the user/ installer by choosing the corresponding position on the **Voltage Switch**, which is the left rotary switch accessible from the outside of the battery indicated by the image below:

Voltage Switch Position	ON Level	OFF Level	Application
0	11.0	10.0	Always on: Ignition Relay/ Signal
1	12.0	11.0	When dealing with extended lengths of thin cable, it is <b>IMPORTANT</b> to consider <b>voltage drops</b> . It is recommended to measure the voltage at both the battery and at the end of the connected cabling. Please see the table on page 10 for recommended cable gauges
2	13.0	12.0	
3	13.3	12.3	
4	13.5	12.5	
5	13.7	12.7	
6	14.0	13.0	



Figure 6 Left Rotary Switch for Measured Voltage Applications outlined in RED.

Table 8 Measured Voltage Switch Position Table

## 9.2 Delay Switch

Delay times can be selected by the user/ installer by choosing the corresponding position on the **Delay Switch**, which is the right rotary switch accessible from the outside of the battery indicated in the image below:

Delay Switch Position	Delay OFF Time	Application
0	0 sec	Traditional Alternator, or Ignition Relay
1	30 sec	Vehicles with Smart Alternators
2	1 min	
3	1.5 min	
4	3 min	
5	5 min	
<b>6*</b>	<b>0 sec</b>	<b>Ignition signal control</b>



Figure 7 Right Rotary Switch for Off Delay Applications outlined in RED.

Table 9 Off Delay Switch Position Table

## 9.3 Off-Delay

After the measured voltage falls BELOW the OFF level, the DC-DC charger will incorporate a delay before turning off (ceasing to charge). This delay is implemented to accommodate smart alternators, which may lower the voltage for brief periods of time (duration may vary based on the drive cycle, vehicle model, and other factors).

During this delay period where the voltage has gone BELOW the OFF level and the DC-DC charger is “waiting” to turn OFF, the status LED will flash to indicate that it will turn off soon.

If the voltage rises ABOVE the ON level within this delay period, the timer will reset, and the DC-DC charger will stay on.

## 9.4 On-Delay

If the Ignition Signal is selected (position **6** on the **Delay Switch**) the DC-DC charger will wait **15 seconds** before turning ON. This delay prevents placing extra load on the start battery before and straight after the engine turns on.

## 9.5 Ignition Signal

If **Position 6** on the **Delay Switch** is selected then the ignition signal (via a separate connection point) will serve as a binary reference (ON or OFF), and there will be no delay. This has 2 benefits:

- ❑ The ignition signal is (usually) a reliable indicator that the engine is running.
- ❑ Voltage drop along the positive power cable is avoided.

The default setting for most applications is 0 on the voltage switch and 6 on the delay switch, this enables DC-DC charging operation to be ON whenever the Ignition is on.

Note that even if the ignition input is used for the measured voltage, there will still be a voltage drop along the negative path to the start battery. If this path is via the vehicle chassis, then voltage drop is likely to be negligible; however, if this negative path is via a long and/or thin cable, then voltage drop may still be a factor.

## 10. Battery Management System

The Power Bank is equipped internally with a Battery Management System (BMS), which is an electronic solid-state circuit board that serves multiple important functions:

- ❑ Battery Cell Management: The BMS manages and maintains the cells within the battery.
- ❑ Safety Measures: The BMS provides safeguards that protect against overcharging and over-discharging and activates in response to situations where the battery is producing low voltage (<10.5V), overcurrent (>100A), or short-circuit situations.
- ❑ Cell Balancing: The BMS ensures that the Power Bank cells are equalised throughout its operation to promote overall efficiency and longevity.
- ❑ Cell Temperature Sensing. If the BMS detects the temperature of the cells to be above 45°C, it will automatically stop charging and discharging until the temperature has returned within the range of 0°C – 45°C.

Unlike lead-acid batteries, overcharging or over-discharging a lithium battery may lead to a hazardous scenario, therefore, the BMS is essential to the lithium battery.

### 10.1 BMS Off Functionality

The BMS is equipped with a remote load disconnecter which can cut off power/ voltage from the main positive and negative terminals. This functionality is intended for isolating remote loads and should only be utilised as a substitute for a dedicated isolator. It can be activated by supplying 12V to PIN 12 of the MCP Connector which will internally disconnect all loads from the battery terminals.

**Please Note:** The activation of this functionality will also disable the battery’s ability to charge.

- ❑ For single or multiple batteries in a switched circuit setup, it is considered best practice to fuse PIN 12 to the main positive with a fuse rated for 1 to 2 Amps. **DO NOT** connect PIN 5.

## 11. Safety Tips

The battery contains Lithium Ferrous Phosphate (LiFePO<sub>4</sub>) cells, considered to be the safest of all lithium-ion chemistries. The battery consists of a large amount of stored energy. Please follow these safety tips for use and operation:

- ❑ Ensure the battery is secured safely before travel.
- ❑ Do not drill into the enclosure. Doing so may inadvertently puncture one of the internal cells.
- ❑ Do not short-circuit the battery. Be careful not to drop a metallic object across the two exposed terminals. Always keep the terminal caps on the Positive (red) and Negative (black) posts during operation.
- ❑ Do not mount the battery upside down. The battery can also be mounted on its side if mounting upright is not an option. Correct battery mounting positions are shown in Table on page 7.
- ❑ Do not connect multiple batteries in series to raise the voltage. The BMS is not designed to accommodate higher voltages.

## 12. Longevity Tips

Factors that mainly affect the lifespan of the battery are depth of discharge and operating temperature. To ensure longevity and use of the battery:

- ❑ Do not fully discharge the battery to zero. Each time the battery is discharged to zero, either intentionally or unintentionally, it reduces the lifespan of the battery.
- ❑ Do not discharge the battery below 80% depth of discharge (i.e., 20% full).
- ❑ Do not charge the battery outside the range 0°C – 45°C to maximize the life of the battery and avoid damage to the cells.
- ❑ Avoid exposing the battery to direct sunlight, mount the battery in a compartment or undercover.

The cells are designed to last 2,000 cycles at 80% DOD (Depth of Discharge) and 5,000 cycles at 50% DOD.

### 13. Tips for Use

- ❑ Batteries of the same voltage may be placed in parallel to increase storage capacity. However, each battery should be independently fused, and the battery must be from **CANGOEE**.
- ❑ If the battery is potentially <0°C it is essential to allow the battery to warm to ambient temperature before connecting power to it.
- ❑ The battery is splash-proof and water resistant but not waterproof, **DO NOT** directly submerge the battery in water.
- ❑ The battery is designed to be housed in a dry, enclosed compartment, not in direct sunlight or exposed to outside weather conditions for an extended period.
- ❑ Only use Lithium Battery Chargers to recharge the battery.

### 14. Maintenance Tips

If not using the battery for a prolonged period (months at a time), then store the battery as follows:

- ❑ Disconnect all loads from the battery so that there is no external current draw.
- ❑ Store the battery close to full capacity (the battery does not need to be at 100%).
- ❑ There is no need to keep the battery on trickle charge. The battery will self-discharge slowly over time.

Within every two months, give the battery a quick recharge to ensure battery longevity.