



CAN22040S2D

Information Guide

MAN0038.2



THIS PAGE IS INTENTIONALLY LEFT BLANK

Table of Contents

1. Safety Precautions.....	5
2. Specifications.....	5
3. Quick Start Guide – CAN22040S2D	6
4. CAN22040S2D Dimensions, and Mounting Orientation	7
5. CAN22040S2D Example Wiring Schematics	9
6. CAN22040S2D Example Use Case Schematics	10
7. Recommended Wire Sizes and Gauges Chart	11
8. DC-DC Charger.....	12
8.1 Measured Voltage	12
8.2 Delay Switch	13
8.3 Off-Delay	13
8.4 On-Delay	13
8.5 Ignition Signal	13
9. Battery Management System	14
10. Victron Connect App	15
11. Victron Energy SmartSolar MPPT 100/20	16
11.1 Solar Panel Array Input Limitations	16
12. Victron Energy SmartShunt 500A/ 50mV.....	17
13. Example Solar Panel Array Configuration	18
13.1 Series Array Configuration.....	18
13.2 Parallel Array Configuration.....	18
14. Safety Tips	19
15. Longevity Tips	20
16. Tips for Use	20
17. Maintenance Tips.....	20

THIS PAGE IS INTENTIONALLY LEFT BLANK

1. Safety Precautions

WARNING

- ☐ Avoid mechanical shock.
- ☐ Avoid direct sunlight exposure.
- ☐ Do not store or mount batteries in incorrect orientations.
- ☐ Do not transport the battery unsecured.
- ☐ Do not expose the battery to water.
- ☐ Do not expose the battery to fire.
- ☐ Do not pierce the battery.
- ☐ Do not disassemble.
- ☐ Do not drill into the battery enclosure.
- ☐ Do not short battery terminals.
- ☐ Do not connect multiple batteries in a series configuration.
- ☐ Do not charge the battery outside the range of 0°C - 45°C.
- ☐ Do not store below -20°C or above 60°C.
- ☐ Risk of burns if misused.
- ☐ Always follow safe working practices.
- ☐ Installation of this device must only be carried out by appropriately qualified competent person(s).
- ☐ All connections must be fused at recommended fuse ratings to avoid damage to components.
- ☐ All minimum cable gauges and maximum lengths must be followed.
- ☐ Only use Lithium Battery Chargers to recharge batteries.

2. Specifications

Cell Type	Lithium Ferrous Phosphate
Total Capacity	220Ah
Nominal Voltage	12.8V
Charge Voltage	13.8 – 14.6V
Float Voltage	13.8V
Charge Current	200A
Discharge Current	200A MAX. Continuous 400A Surge
DC-DC Charger	40A
Operating Temp	0°C -45°C
Dimensions (LxWxD)	990mm x 269.5mm x 112.35mm
Solar – Victron SmartSolar MPPT	Max Voc 100V/ Max Isc 20A
Victron Smart Shunt	500A/50mV

Table 1 CAN22040S2D Power Hub Specifications

Product Number	Version	Version Date
CAN22040S2D	R5	28 – May – 2024

This document is electronically controlled. Any printed copies of this document may be used for reference but unless they are clearly marked as "Controlled Document" they are to be treated as uncontrolled documents.

3. Quick Start Guide – CAN22040S2D

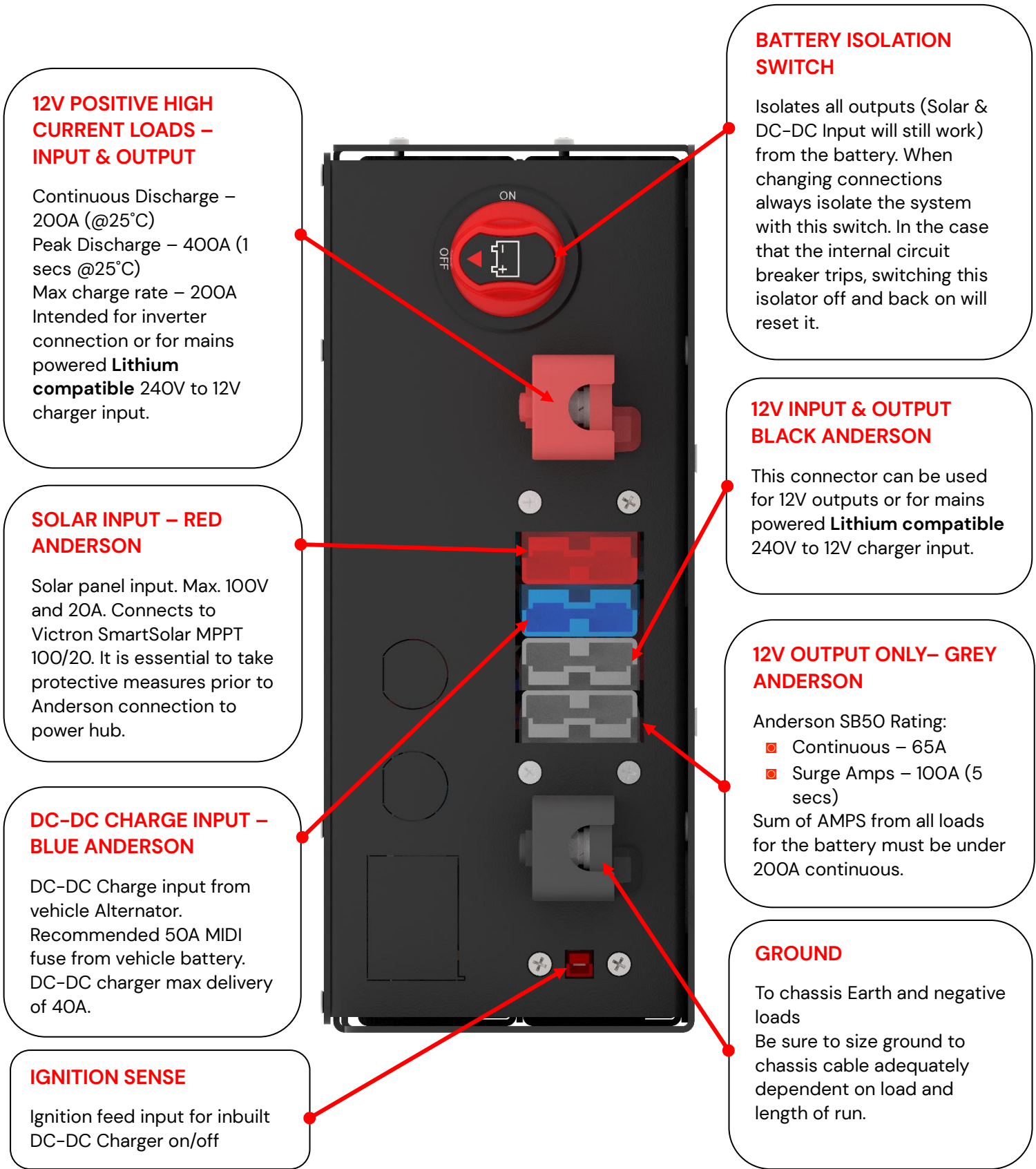

Figure 1 CAN22040S2D Power Hub Connection Description

Product Number	Version	Version Date
CAN22040S2D	R5	28 – May – 2024

This document is electronically controlled. Any printed copies of this document may be used for reference but unless they are clearly marked as "Controlled Document" they are to be treated as uncontrolled documents.

4. CAN22040S2D Dimensions, and Mounting Orientation

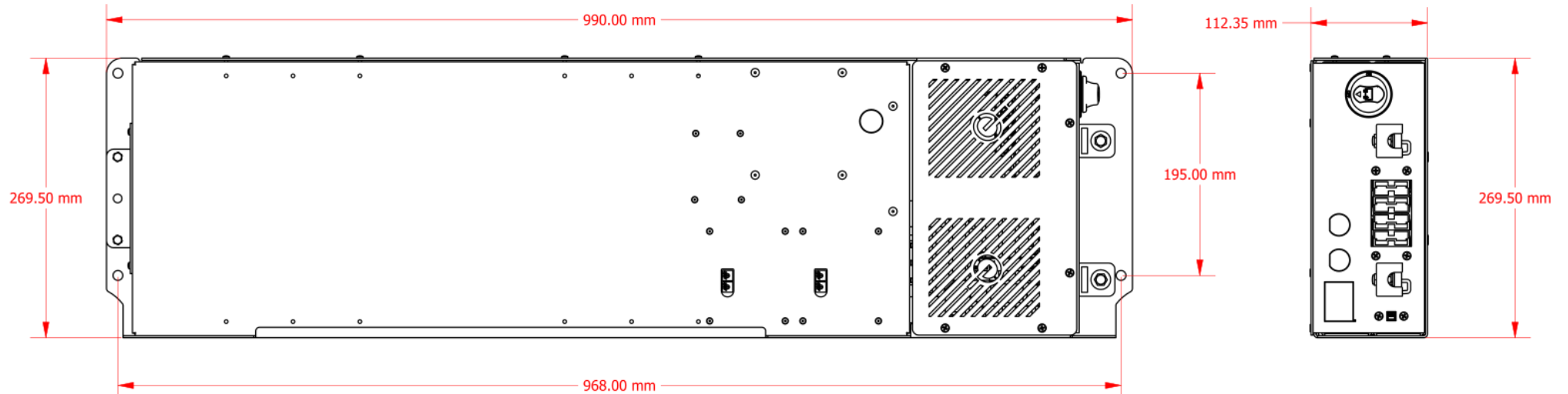

Figure 2 CAN22040S2D Power Hub Dimensions

Product Number	Version	Version Date
CAN22040S2D	R5	28 – May – 2024

This document is electronically controlled. Any printed copies of this document may be used for reference but unless they are clearly marked as "Controlled Document" they are to be treated as uncontrolled documents.

EXAMPLE MOUNTING ORIENTATIONS

CORRECT Mounting Orientation

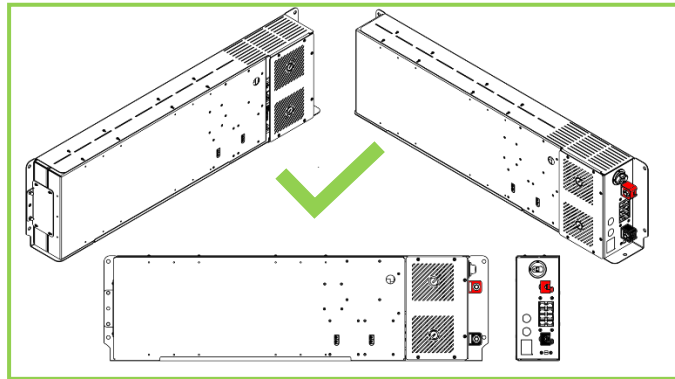

Vertical on long edge with POSITIVE Terminal furthest from the ground.

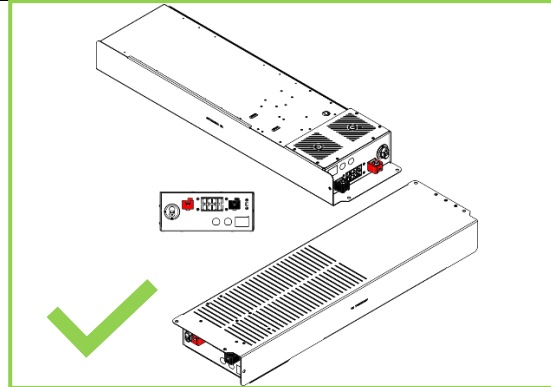

Flat mounting orientation.

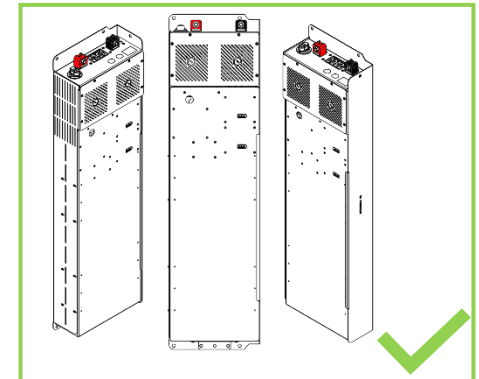

Vertical on short edge with terminals pointing towards the sky.

INCORRECT Mounting Orientation

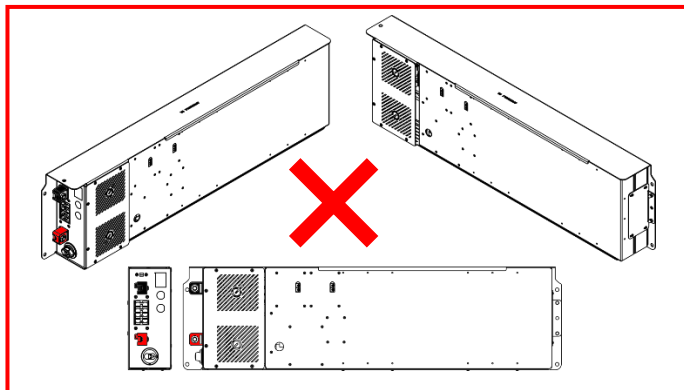

Vertical on long edge with POSITIVE Terminal closest to the ground.

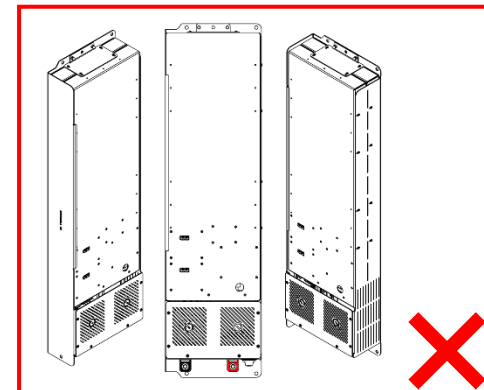

Vertical on short edge with terminals pointing towards the ground.

Please Note: Rotary selector switches should ideally be set before installation of the Power Hub as access may be difficult after installation. Please see pages 12 and 13 for details on the rotary selector switch position settings.

Table 2 CAN22040S2D Power Hub Mounting Orientation

Product Number	Version	Version Date
CAN22040S2D	R5	28 – May – 2024

This document is electronically controlled. Any printed copies of this document may be used for reference but unless they are clearly marked as "Controlled Document" they are to be treated as uncontrolled documents.

5. CAN22040S2D Example Wiring Schematics

To fully disconnect the Power Hub, the ISOLATOR Switch must be turned off before any disconnections are made.

For systems that have solar inputs – the solar input connections must be externally protected with a dual-pole DC breaker switch and should be switched off before the ISOLATOR Switch on the power hub. Once turned off, the red Anderson SB50 plug used for solar input can be removed to disconnect solar inputs.

Please Note: An external shunt is not required as a smart shunt is pre-built within the system.

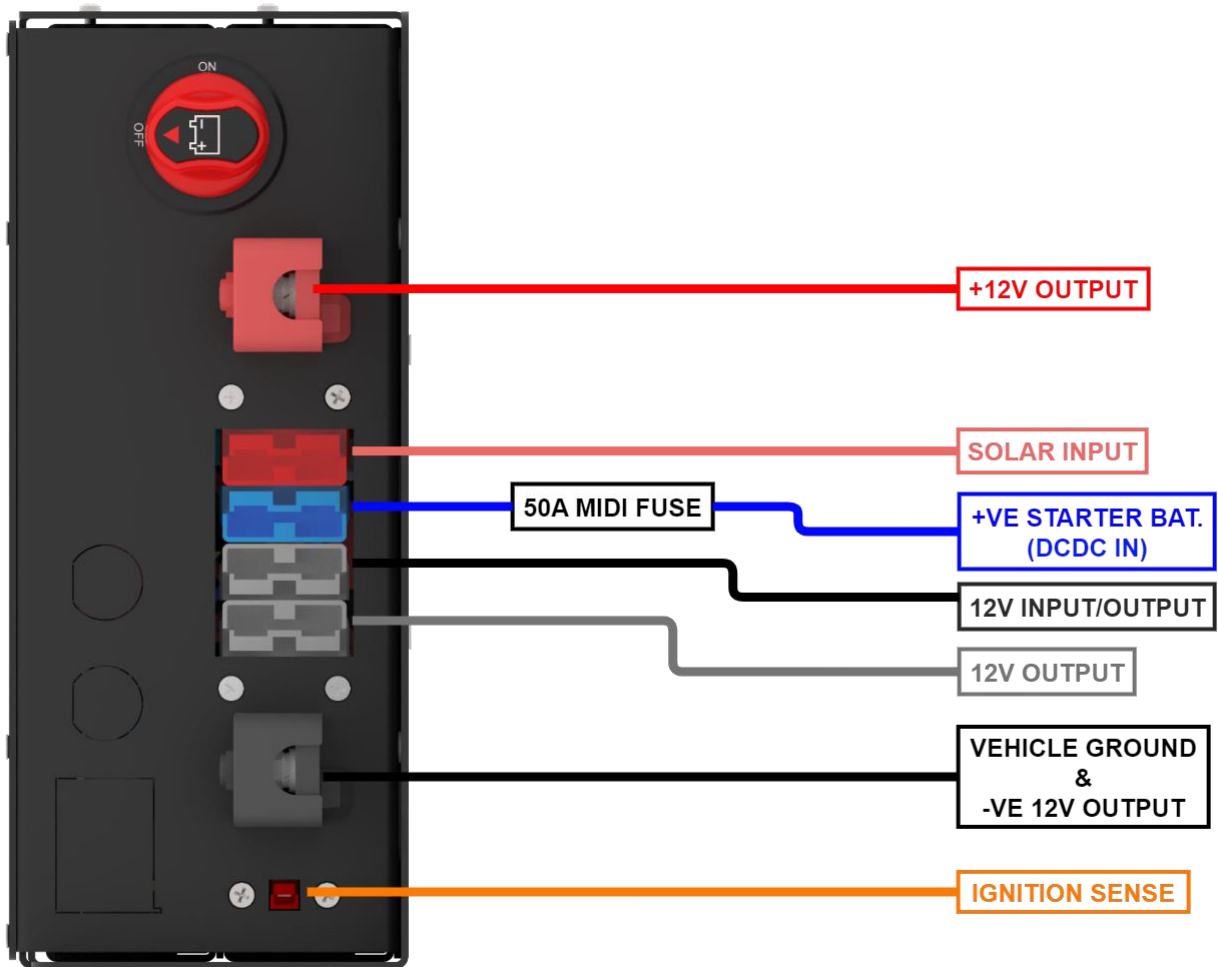

Figure 3 CAN22040S2D Power Hub Example Wiring Schematic

6. CAN22040S2D Example Use Case Schematics

Please Note: This is for illustration purposes only and is **NOT** intended to be used as a guide for installation.

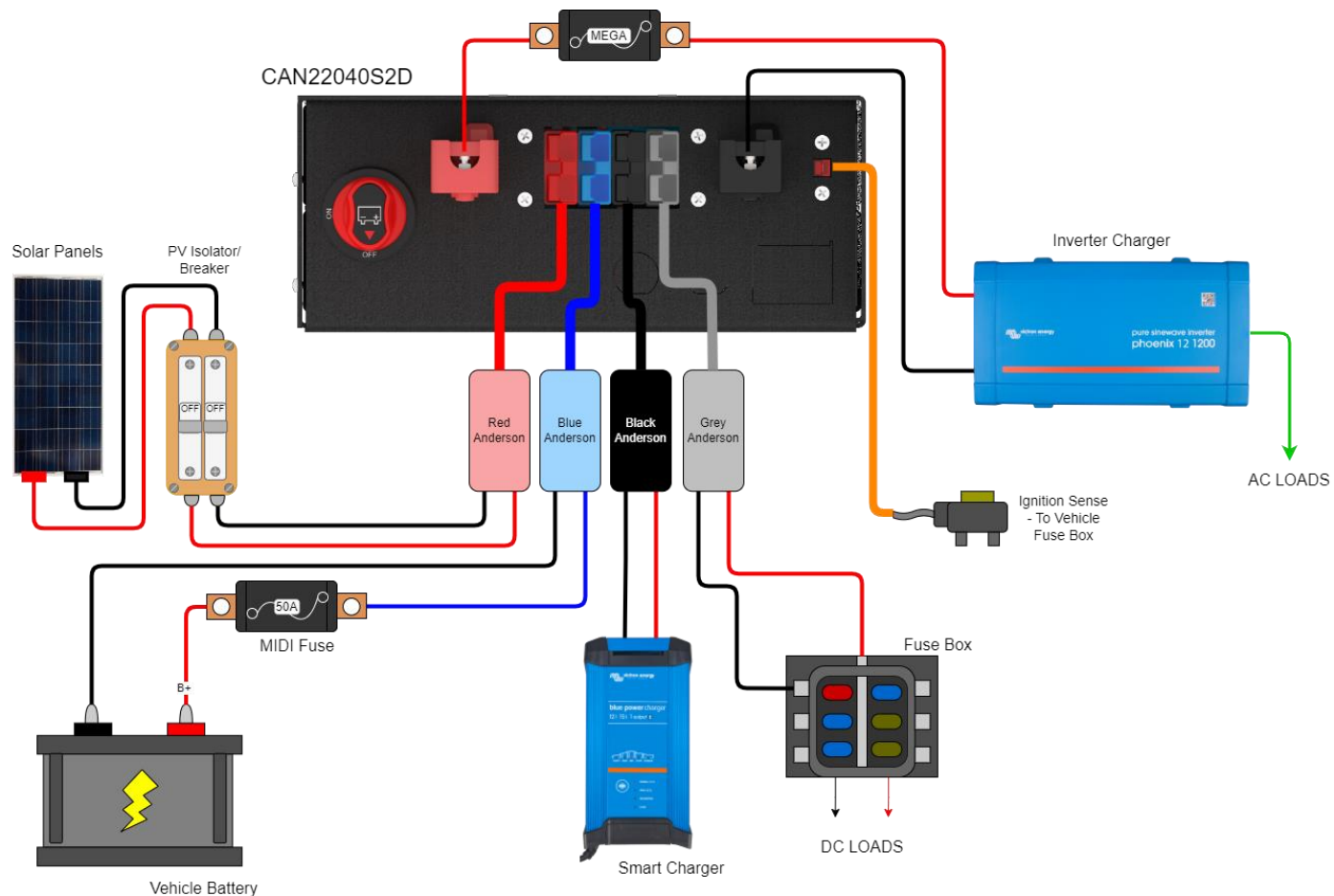

Figure 4 Example Use Case of CAN22040S2D Power Hub

Product Number	Version	Version Date
CAN22040S2D	R5	28 – May – 2024

This document is electronically controlled. Any printed copies of this document may be used for reference but unless they are clearly marked as "Controlled Document" they are to be treated as uncontrolled documents.

7. Recommended Wire Sizes and Gauges Chart

The below table represents the recommended wire sizes/ gauges, for battery installation into vehicles.

DCDC Capacity/ Cable	Recommended Wire Size/ Gauge Figure 8 Cable	Recommended Wire Length
DC-DC 20A	8 B&S/ AWG (CSA 7.71mm ²)	1m- Up to/ Maximum 5m
DC-DC 40A	6 B&S/ AWG (CSA 13.5mm ²)	1m – Up to/ Maximum 5m
Ignition Sense Cable	18-14 B&S/ AWG (CSA 0.64mm ² – 1.84mm ²) (Running a max of 1-2 Amps)	1m – Up to/ Maximum 6m
Main Positive +	6 B&S/ AWG (CSA 13.5mm ²) to 1 B&S/ AWG (CSA 42.4mm ²) 80A – 120A current carrying capacity	1m – Up to/ Maximum 4m
Main GND –	6 B&S/ AWG (CSA 13.5mm ²) to 1 B&S/ AWG (CSA 42.4mm ²) 80A – 120A current carrying capacity	1m – Up to/ Maximum 4m

Table 3 Recommended Wire Sizes and Gauges

Please Note: These wire gauges are suggested to mitigate the voltage drop along the cable. It is recommended that you check the voltage at the battery’s DC-DC input and alter charger selector switches accordingly.

8. DC-DC Charger

The DC-DC charger in the Power Hub allows the battery to charge from a vehicle engine/alternator/start battery. However, to prevent the depletion of the start battery, it is essential to limit charging to when the engine is actively running.

In some scenarios, determining when the engine is actively operating can be challenging. As a solution, the DC-DC charger uses a combination of inputs to decide when to initiate charging (turn ON) and when to cease charging (turn OFF). The primary goals of the charger are:

- ❑ Ensuring that charging occurs only when the engine is actively running, to maximise charging of the Power Hub.
- ❑ Preventing charging when the engine is not running to avoid discharging the vehicle's start/cranking battery.

The logic for controlling when to activate or deactivate the DC-DC charger is executed through specialised software running on a microcontroller. This software allows for advanced control by considering several inputs including:

- ❑ Start battery voltage.
- ❑ Ignition signal voltage.
- ❑ Timing delays.
- ❑ Positions of 2 x 7-position (0-6) rotary switches: user-accessible from outside the battery.

8.1 Measured Voltage

The vehicle's start battery/alternator voltage will be measured with high precision, accurate to $\pm 0.1V$ or better, and used as a reference for comparison with the ON and OFF levels.

The DC-DC Charger will be activated (start charging) when the **Measured Voltage** goes ABOVE the **ON Level**. Thereafter it will deactivate after the **Measured Voltage** goes BELOW the **OFF Level**.

The OFF level is lower than the ON Level by 1.0V; this forms a "dead-band" where the charger will simply remain in the same state (i.e., remain ON if already ON, and remain OFF if already OFF).

ON and OFF Levels can be selected by the user/installer by choosing the corresponding position on the **Voltage Switch**, which is the left rotary switch accessible from the outside of the battery indicated by the image below:

Voltage Switch Position	ON Level	OFF Level	Application
0	11.0	10.0	Always on: Ignition Relay/ Signal
1	12.0	11.0	When dealing with extended lengths of thin cable, it is IMPORTANT to consider voltage drops . It is recommended to measure the voltage at both the battery and at the end of the connected cabling. Please see the table on page 11 for recommended cable gauges
2	13.0	12.0	
3	13.3	12.3	
4	13.5	12.5	
5	13.7	12.7	
6	14.0	13.0	



Figure 5 Left Rotary Switch for Measured Voltage Applications outlined in RED.

Table 4 Measured Voltage Switch Position Table

8.2 Delay Switch

Delay times can be selected by the user/installer by choosing the corresponding position on the **Delay Switch**, which is the right rotary switch accessible from the outside of the battery indicated in the image below:

Delay Switch Position	Delay OFF Time	Application
0	0 sec	Traditional Alternator, or Ignition Relay
1	30 sec	Vehicles with Smart Alternators
2	1 min	
3	1.5 min	
4	3 min	
5	5 min	
6*	0 sec	Ignition signal control

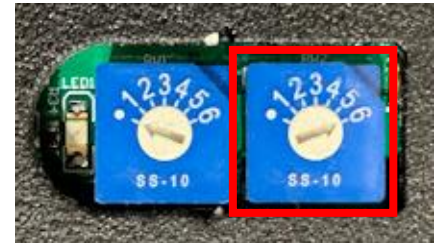

Figure 6 Right Rotary Switch for Off Delay Applications outlined in RED.

Table 5 Off Delay Switch Position Table

8.3 Off-Delay

After the measured voltage falls BELOW the OFF level, the DC-DC charger will incorporate a delay before turning off (ceasing to charge). This delay is implemented to accommodate smart alternators, which may lower the voltage for brief periods of time (duration may vary based on the drive cycle, vehicle model, and other factors).

During this delay period where the voltage has gone BELOW the OFF level and the DC-DC charger is “waiting” to turn OFF, the status LED will flash to indicate that it will turn off soon.

If the voltage rises ABOVE the ON level within this delay period, the timer will reset, and the DC-DC charger will stay on.

8.4 On-Delay

If the Ignition Signal is selected (position **6** on the **Delay Switch**) the DC-DC charger will wait **15 seconds** before turning ON. This delay prevents placing extra load on the start battery before and straight after the engine turns on. There is no On-Delay for other positions as the DC-DC Charger will monitor the vehicle start battery/alternator voltage to operate.

8.5 Ignition Signal

If **Position 6** on the **Delay Switch** is selected then the ignition signal (via a separate connection point) will serve as a binary reference (ON or OFF), and there will be no delay when turning off. This has two benefits:

- ☑ The ignition signal is (usually) a reliable indicator that the engine is running.
- ☑ Voltage drop considerations along the positive DC-DC charging cable are not required.

The default setting for most applications is 0 on the voltage switch and 6 on the delay switch, this enables DC-DC charging operation to be ON 15 seconds after the Ignition is on.

Note that even if the ignition signal is used for the measured voltage, there will still be a voltage drop along the negative path of the DC-DC charging cable to the start battery. Voltage drop is likely to be negligible along vehicle chassis, however, if the negative path is via a long and/or thin cable, then voltage drop may still be a factor and needs to be considered.

9. Battery Management System

The Power Hub is equipped internally with a Battery Management System (BMS), which is an electronic solid-state circuit board that serves multiple important functions:

- ❑ **Battery Cell Management:** The BMS manages and maintains the cells within the battery.
- ❑ **Safety Measures:** The BMS provides safeguards that protect against overcharging and over-discharging and activates in response to situations where the battery is producing low voltage (less than 10.5V), overcurrent (more than 100A), or short-circuit situations.
- ❑ **Cell Balancing:** The BMS ensures that the Power Hub cells are equalised throughout its operation to promote overall efficiency and longevity.
- ❑ **Cell Temperature Sensing.** If the BMS detects the temperature of the cells to be above 45°C, it will automatically stop charging and discharging until the temperature has returned within the range of 0°C – 45°C.

Unlike lead-acid batteries, overcharging or over-discharging a lithium battery may lead to a hazardous scenario, therefore, the BMS is essential to the lithium battery.

10. Victron Connect App

Download the Victron Connect application onto your smart device to access and manage the Power Hub's Victron Energy Components.

Victron Connect info:

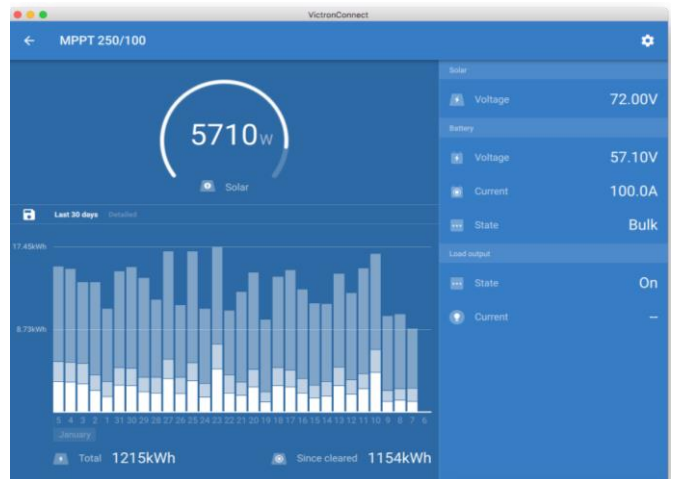

11. Victron Energy SmartSolar MPPT 100/20



Victron Energy SmartSolar MPPT 100/20	
Manual	Datasheet

The Victron Energy SmartSolar MPPT 100/20 model is a compact and highly efficient solar charge controller, ideal for optimizing solar power systems. It offers advanced Maximum Power Point Tracking (MPPT) technology to maximize the energy harvested from your solar panels.

11.1 Solar Panel Array Input Limitations

MAX OPEN CIRCUIT VOLTAGE (Voc): 100 V

It is recommended to stay at least 10% below the rated maximum open circuit voltage (Voc)

MAX SHORT CIRCUIT CURRENT (Isc): 20 A

Pre-set and suggested programming settings in the Victron Connect Application

Victron Connect → SmartSolar MPPT 100/20 → ⚙️ (Settings) → Battery

Settings	
Battery voltage	12V
Max charge current	20A
Charger enabled	<input checked="" type="checkbox"/>
Battery preset	User defined ▾
Expert mode	<input type="checkbox"/>
Charge voltages	
Absorption voltage	14.40V
Float voltage	13.80V
Equalization voltage	13.80V
Equalization	
Automatic equalization	Disabled
Voltage compensation	
Temperature compensation	-16.20mV/°C
Battery limits	
Low temperature cut-off	Disabled

Table 6 Pre-set and Suggested Programming Settings in the Victron Connect Application for SmartSolar MPPT

12. Victron Energy SmartShunt 500A/ 50mV



Victron Energy SmartShunt 500A/ 50mV	
Manual	Datasheet

The Victron Energy SmartShunt is an all in one battery monitor, only without a display. A smartphone can be utilised as a display. The SmartShunt connects via Bluetooth to the VictronConnect app on the smart device and conveniently displays all monitored battery parameters.

Pre-set and suggested programming settings in the Victron Connect Application	
Victron Connect → SmartShunt 500A/ 50mV → ⚙️ (Settings) → Battery	
← Battery settings	
Battery capacity	220Ah
Charged voltage	14.0V
Discharge floor	20%
Tail current	1.00%
Charged detection time	3m
Peukert exponent	1.05
Charge efficiency factor	99%
Current threshold	0.10A
Time-to-go averaging period	3m
Battery SOC on reset	<input type="button" value="Keep SOC"/>
State-of-Charge	85.0%
Manually set the current state-of-charge	
Synchronize SOC to 100%	<input type="button" value="Synchronize"/>
Zero current calibration	<input type="button" value="Calibrate"/>

Table 7 Pre-set and Suggested Programming Settings in the Victron Connect Application for SmartShunt

13. Example Solar Panel Array Configuration

Please Note: This page is intended for illustrative purposes only and NOT intended as a guide for installation. Solar panel installation must be undertaken by a qualified person(s).

Example 325W Solar Panel		
Max Power Output	P _{max}	325 W
Max Power Voltage	V _{mp}	37.5 V
Max Power Current	I _{mp}	8.75 A
Open Circuit Voltage	V _{oc}	45 V
Short Circuit Current	I _{sc}	10 A



Figure 7 Solar Panel

13.1 Series Array Configuration

Solar Panels that are connected in a series configuration will result in the summation of the voltages while the current flowing throughout the circuit remains the same.

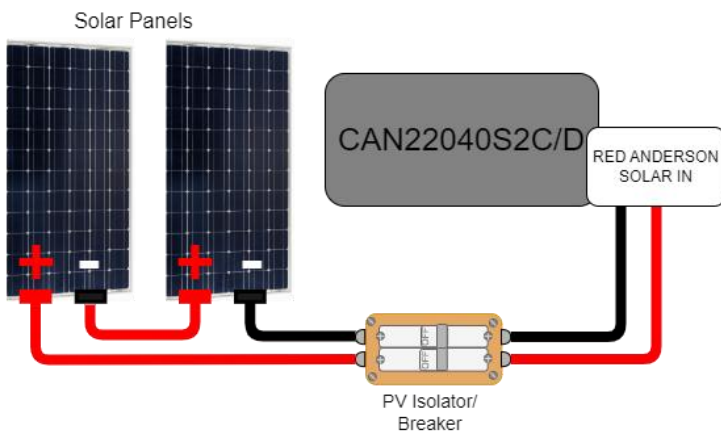

Figure 8 Example Series Configuration of Solar Panel Array

Example Output from Solar Panel Array in Series Configuration	
Max Power Voltage	37.5 + 37.5 = 75 V
Open Circuit Voltage	45 + 45 = 90 V (Within max Voc limitations)
Current	8.75 A
Short Circuit Current	10 A
Watts	75 V * 8.75 A ≈ 660W

13.2 Parallel Array Configuration

Solar Panels that are connected in a parallel configuration will result in the summation of the current while the voltage across all components within the circuit remains the same.

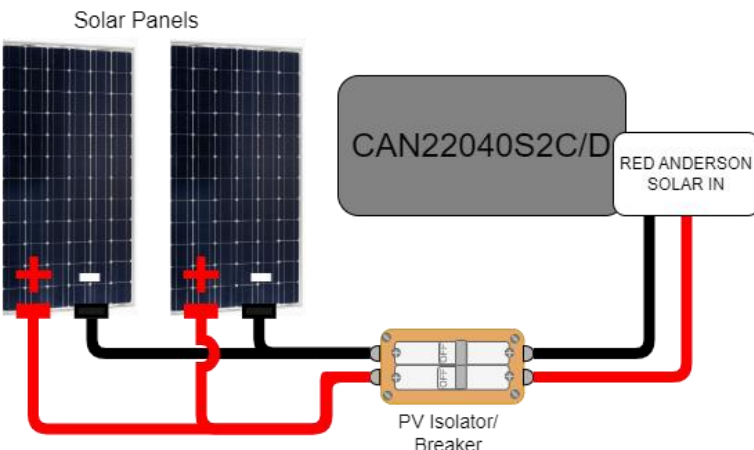

Figure 9 Example Parallel Configuration of Solar Panel Array

Example Output from Solar Panel Array in Parallel Configuration	
Max Power Voltage	37.5 V
Open Circuit Voltage	45 V
Current	8.75 + 8.75 = 17.5 A
Short Circuit Current	10 + 10 = 20 A (Within max Isc limitations)
Watts	37.5 V * 17.5 A ≈ 660W

14. Safety Tips

The battery contains Lithium Ferrous Phosphate (LiFePO₄) cells, considered to be the safest of all lithium-ion chemistries. The battery consists of a large amount of stored energy. Please follow these safety tips for use and operation:

- ❑ Ensure the battery is secured safely before travel.
- ❑ Do not drill into the enclosure. Doing so may inadvertently puncture one of the internal cells.
- ❑ Do not short-circuit the battery. Be careful not to drop a metallic object across the two exposed terminals. Always keep the terminal caps on the Positive (red) and Negative (black) posts during operation.
- ❑ Do not mount the battery upside down. The battery can also be mounted on its side if mounting upright is not an option. Correct battery mounting positions are shown in Table on page 8.
- ❑ Do not connect multiple batteries in series to raise the voltage. The BMS is not designed to accommodate higher voltages.

15. Longevity Tips

Factors that mainly affect the lifespan of the battery are depth of discharge and operating temperature. To ensure longevity and use of the battery:

- ❑ Do not fully discharge the battery to zero. Each time the battery is discharged to zero, either intentionally or unintentionally, it reduces the lifespan of the battery.
- ❑ Do not discharge the battery below 80% depth of discharge (i.e., 20% full).
- ❑ Do not charge the battery outside the range 0°C – 45°C to maximize the life of the battery and avoid damage to the cells.
- ❑ Avoid exposing the battery to direct sunlight, mount the battery in a compartment or undercover.

The cells are designed to last 2,000 cycles at 80% DOD (Depth of Discharge) and 5,000 cycles at 50% DOD.

16. Tips for Use

- ❑ Batteries of the same voltage may be placed in parallel to increase storage capacity. However, each battery should be independently fused, and the battery must be from **CANGOEE**.
- ❑ If the battery temperature is potentially less than 0°C it is essential to allow the battery to warm to ambient temperature before connecting power to it.
- ❑ The battery is splash-proof and water resistant but not waterproof, **DO NOT** directly submerge the battery in water.
- ❑ The battery is designed to be housed in a dry, enclosed compartment, not in direct sunlight or exposed to outside weather conditions for an extended period.
- ❑ Only use Lithium Battery Chargers to recharge the battery.

17. Maintenance Tips

If not using the battery for a prolonged period (months at a time), then store the battery as follows:

- ❑ Disconnect all loads from the battery so that there is no external current draw.
- ❑ Ensure the battery is close to full capacity as the battery will slowly self-discharge over time.
- ❑ Do not keep the battery on trickle charge as this may harm the internal battery cells.

Within every two months, give the battery a quick recharge to ensure battery longevity.